

Overview 1

Hardware Setup 2

- Power Considerations 2
- Card Configuration 2
- 5B Module Connection 3
- Terminal Block Connection 4
- P1 Connection 4
- CE Compliance 5
- DaqBook and DaqBoard [ISA type] Configuration 5

Software Setup 5

mx+b Values for 5B Modules 6

DBK44 – Specifications 7



Reference Notes:

- Refer to [Chapter 2, Power Management](#), in regard to calculating system power requirements.
- [Chapter 3, System Connections and Pinouts](#), includes pinouts for P1, P2, P3, and P4. Refer to the pinouts that are applicable to your system, as needed.



Reference Note:

Users of the DBK44 signal-conditioning card may be interested in the [DBK207](#) and [DBK207/CJC](#), *Carrier Boards for 5B Compatible Analog I/O Modules*. Each DBK207 and DBK207/CJC board includes a 100-pin P4 connector for DaqBoard/2000 Series and /2000c Series compatibility, two P1 connectors for analog expansion, a power connection terminal, and 16 signal terminal blocks. In addition, the DBK207/CJC board includes CJC (Cold Junction Compensation) for thermocouple applications. DBK207 and DBK207/CJC can be mounted in Nema-type panels.

Overview

The 2-channel DBK44 allows LogBook or Daq device systems to use any combination of 5B signal-conditioning modules. 5B modules can accommodate a variety of signals (low-level thermocouple signals to strain-gage signals, etc). Configuration options are flexible. You can select the type of signal attached to each channel. One LogBook or Daq device can support up to 128 DBK44 cards, providing up to 256 isolated, analog input channels.

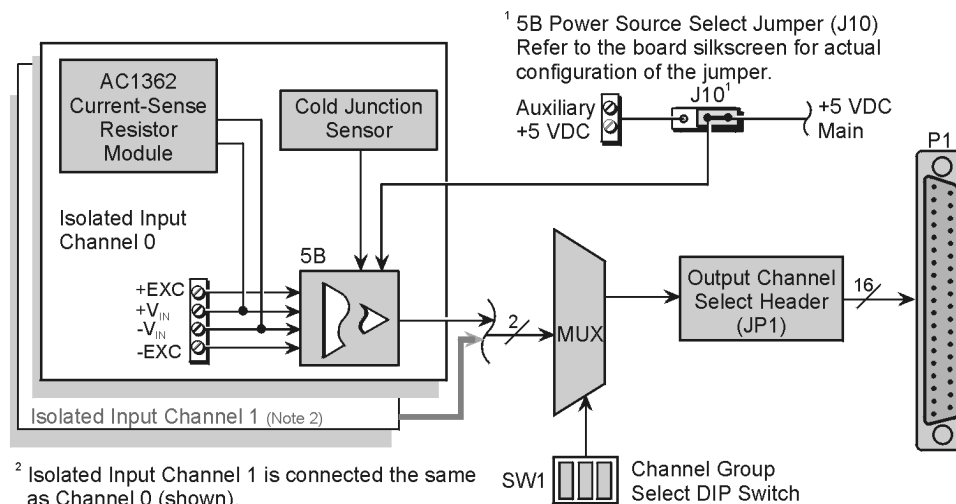

DBK44 Block Diagram

The LogBook or Daq device scans the DBK44's channels at the same 10 μ s/channel rate as other DBKs (256 scans in 2.56 ms in a full system). Each user-installed 5B module offers 500 V isolation from the system and between channels. The DBK44 has convenient screw-terminal blocks for signal inputs and excitation outputs (for use with a strain gage or RTD). Cold junction compensators (CJC) are installed and ready to use with thermocouple 5B modules. Sockets are provided for AC1362 current-sense resistor modules.

Hardware Setup

Power Considerations

The DBK44 requires +5 and ± 15 VDC from a LogBook, Daq device P1 connector, or auxiliary power supply. In some applications, the DBK44 can draw enough power from the LogBook's internal power supply via the P1 connector. However, the 5B power requirements (+5 VDC only) may be greater than the LogBook or DaqBook/DaqBoard can provide (see table). The Daq PC-Card must use a CDK10 Power Module.

5B Model	Current Required
5B30	30 mA
5B31	30 mA
5B32	30 mA
5B34	30 mA
5B37	30 mA
5B38	200 mA
5B39	*170 mA
5B40	30 mA
5B41	30 mA
5B47	30 mA
* Maximum output load resistance is 750 Ω	



For applications with more than 4 channels, it may be better to use the DBK42 instead of the DBK44. The DBK42 is a 16-channel module with a built-in power supply.

External power can be obtained from any regulated 5 V source or from a TR-4 power supply. External power attaches to the DBK44 via onboard screw-terminal connections (the Auxiliary Power Input J9 Combicon terminal at the rear of the board).



The 5B38 series strain-gage modules with excitation output require an external power source. Auxiliary power is also necessary in systems equipped with more than one DBK44. Prior to using auxiliary power, you must select AUXL on the Power Source Select Jumper (J10).

CAUTION



Auxiliary power input must not exceed +5 VDC. DBK44 does not regulate auxiliary power input.

Card Configuration

Up to 128 DBK44s may connect to a LogBook or a Daq device system. Since this is a daisy-chain interface, each module must appear unique and use a different analog input channel. To configure the card's channel, you must set the JP1 jumper and the SW1 DIP switch to your chosen channel as follows.

1. Locate the 16x2-pin header (labeled JP1) near the front of the card. Note the 16 jumper locations labeled CH0 through CH15 to match the main channel.
2. Place the JP1 jumper on the channel you wish to use. Only one jumper is used per card, but up to 8 DBK44s can occupy one main channel and use the same JP1 setting (but with different SW1 settings).
3. Locate the SW1 DIP switch that serves as a channel group select switch and can distinguish up to 8 cards on a channel.
4. Place the 3 mini switches (CBA) in the position that corresponds to your chosen channel as shown in the table below. For each JP1 setting, there are 8 possible SW1 settings to allow two input channels per card).

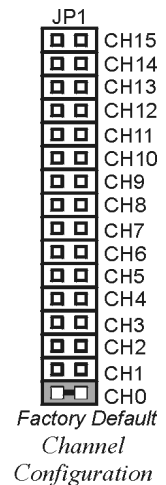

Channel Pair Determined by JP1 and SW1								
JP1 Jumper	SW1 DIP Switch Setting							
	CBA	CBA	CBA	CBA	CBA	CBA	CBA	CBA
	0 0 0	0 0 1	0 1 0	0 1 1	1 0 0	1 0 1	1 1 0	1 1 1
CH0	16-17	18-19	20-21	22-23	24-25	26-27	28-29	30-31
CH1	32-33	34-35	36-37	38-39	40-41	42-43	44-45	46-47
CH2	48-49	50-51	52-53	54-55	56-57	58-59	60-61	62-63
CH3	64-65	66-67	68-69	70-71	72-73	74-75	76-77	78-79
CH4	80-81	82-83	84-85	86-87	88-89	90-91	92-93	94-95
CH5	96-97	98-99	100-101	102-103	104-105	106-107	108-109	110-111
CH6	112-113	114-115	116-117	118-119	120-121	122-123	124-125	126-127
CH7	128-129	130-131	132-133	134-135	136-137	138-139	140-141	142-143
CH8	144-145	146-147	148-149	150-151	152-153	154-155	156-157	158-159
CH9	160-161	162-163	164-165	166-167	168-169	170-171	172-173	174-175
CH10	176-177	178-179	180-181	182-183	184-185	186-187	188-189	190-191
CH11	192-193	194-195	196-197	198-199	200-201	202-203	204-205	206-207
CH12	208-209	210-211	212-213	214-215	216-217	218-219	220-221	222-223
CH13	224-225	226-227	228-229	230-231	232-233	234-235	236-237	238-239
CH14	240-241	242-243	244-245	246-247	248-249	250-251	252-253	254-255
CH15	256-257	258-259	260-261	262-263	264-265	266-267	268-269	270-271

5B Module Connection

Each input of the DBK44 is processed through a user-installed 5B signal-conditioning module. Different 5B modules are used with different transducer and signal sources. To install the modules:

1. Remove all power from the DBK44.
2. Match the footprint of the module with the footprint on the circuit board (see figure).
3. Gently place the module into the footprint, and screw it down.
4. Record the channel the module was placed in.

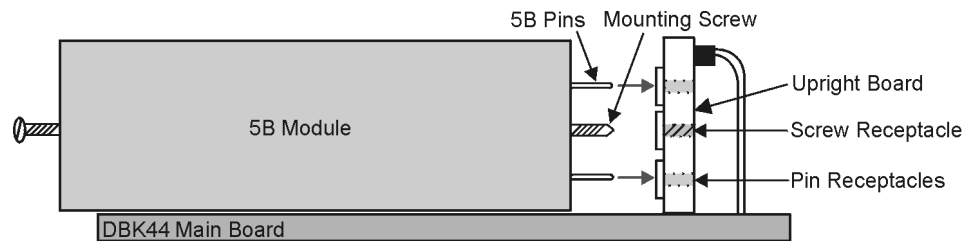

5B Module Installation

When installing current input modules (SC-5B32 series), be sure to install the current-sense resistor (SC-AC-1362 shipped with the SC-5B32) in the resistor socket (J4 for ch 0, J3 for ch 1) near the input screw-terminal block (see figure).



Install Current-Sense Resistor

Terminal Block Connection

WARNING



Shock Hazard. De-energize circuits connected to the DBK44 before changing the wiring or configuration. The DBK44 is designed to sense signals that may carry dangerous voltages.

Input signals (and excitation leads) must be wired to the DBK44 via the 4-contact terminal blocks at the end of the card. These terminal blocks connect internally to their corresponding signal conditioning module. The terminal blocks accept up to 14-gage wire into quick-connect screw terminals that are labeled as to their function. Each type of input signal or transducer (such as a thermocouple or strain gage) should be wired to its terminal block as shown in the figure. Wiring is shown for RTDs, thermocouples, 20 mA circuits, mV/V connections, and for full- and half-bridge strain gages.

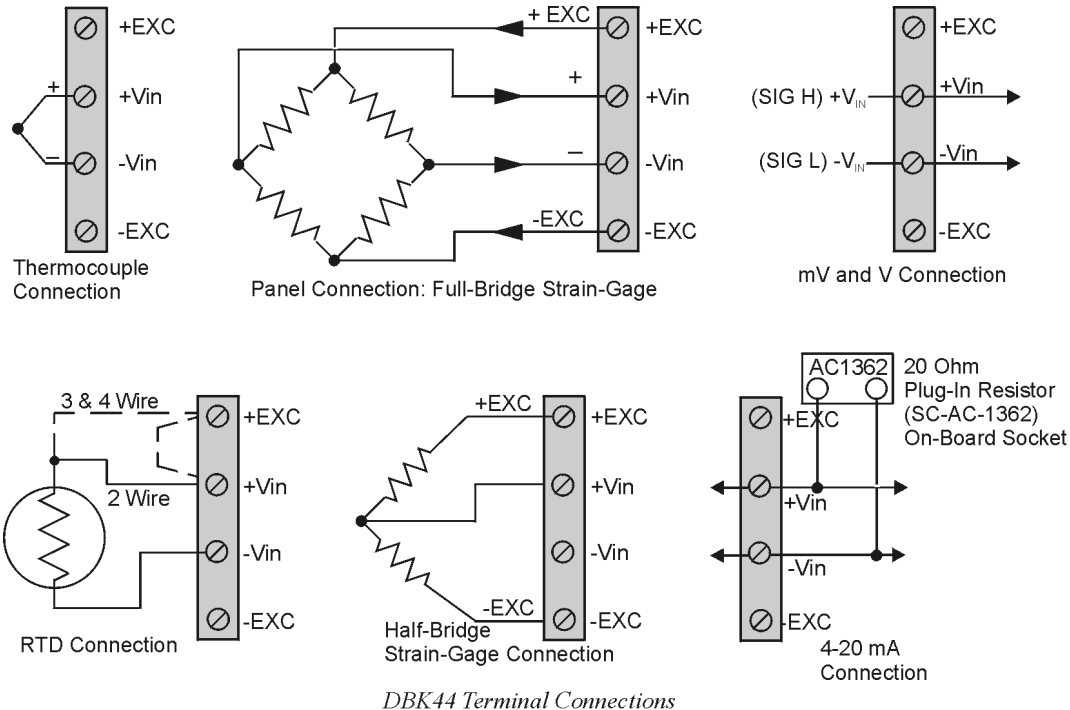

P1 Connection



Reference Notes:

[Chapter 3, System Connections and Pinouts](#), includes pinouts for P1, P2, P3, and P4.

Refer to the pinouts that are applicable to your system, as needed.

The DBK44 attaches to the LogBook's or Daq Device's P1 analog I/O connector. Connect the CA-37-x accessory ribbon cable (with x indicating the number of cards to be connected) from P1 to the DB37 connector at the end of the DBK44 card.

Note: A series of interface cables are available to connect up to 128 DBK44s. You can also use a DBK41 10-slot expansion chassis.

DBK44 can be connected to the P1 connector of DBK200, DBK201, DBK202, or DBK203. Connect the CA-37-x accessory ribbon cable (with x indicating the number of cards to be connected) from P1 to the DB37 connector at the end of the DBK44 card.

Note: Interface cables are available to connect up to 128 DBK44s.

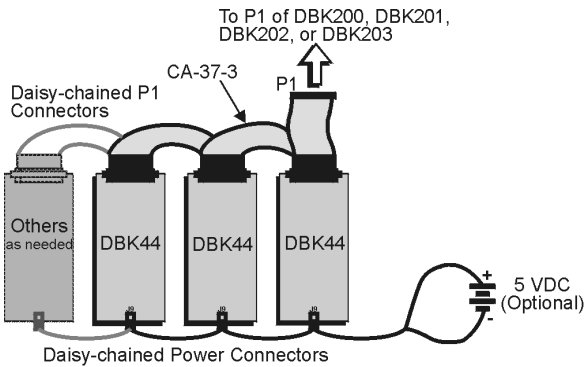

Daisy-Chaining DBK44 Cards

CE Compliance



Reference Notes:

Should your data acquisition system need to comply with CE standards, refer to the *CE Compliance* section of Chapter 1.



DaqBook and DaqBoard [ISA type] Configuration

The DBK44 requires two setup steps in DaqBooks and DaqBoards [ISA type]—jumpers JP1 and JP4.

1. If not using auxiliary power, ensure the JP1 jumper is configured for Analog Option Card Use (expanded analog mode).

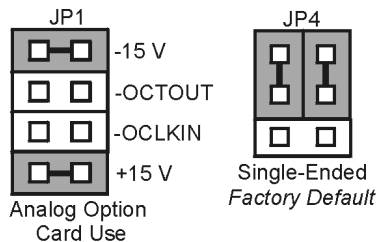

DaqBook/DaqBoard Jumpers for DBK44

Note: This default position is necessary to power the interface circuitry of the DBK44 via the internal ± 15 VDC power supply. If using auxiliary power from a DBK32A or DBK33 card, you must remove both JP1 jumpers. Refer to chapter 2, *Power Management* to the DBK32A and DBK33 document modules, as applicable.

2. For DaqBook/100, /112, and /120 *only*, place the JP4 jumper in the DaqBook or DaqBoard [ISA type] in *single-ended* mode. Note that analog expansion cards convert all input signals to single-ended voltages referenced to analog common.

Note: The configuration of the JP3 jumper depends on the output range of the 5B module. For example, a 5B31 volt input module has an output range of -5 to +5 V in bipolar mode. A 5B47 T/C module (output 0 to +5 V) could use bipolar mode, but unipolar mode is more appropriate.

Software Setup



Reference Notes:

- **DaqView users** - Refer to [Chapter 4, DBK Setup in DaqView](#).
- **LogView users** - Refer to [Chapter 5, DBK Setup in LogView](#).

mx+b Values for 5B Modules

The $mx+b$ values for many 5B modules are included within LogView; some are shown in table below.

5B Module	m Value	b Value	Engineering Unit(s)
Isolated Voltage Input (5 V Current Requirement, 30 mA)			
SC-5B31-01	1/5	0	mV, V
SC-5B31-02	1	0	mV, V
SC-5B31-03	2	0	mV, V
SC-5B31-04	2/5	-1	mV, V
SC-5B31-05	2	-5	mV, V
SC-5B31-06	4	-10	mV, V
Isolated Wideband Voltage (5 V Current Requirement, 30mA)			
SC-5B41-01	1/5	0	V
SC-5B41-02	1	0	V
SC-5B41-03	2	0	V
SC-5B41-04	2/5	-1	V
SC-5B41-05	2	-5	V
SC-5B41-06	4	-10	V
Isolated Millivolt Input (5 V Current Requirement, 30 mA)			
SC-5B30-01	2	0	mV
SC-5B30-02	10	0	mV
SC-5B30-03	20	0	mV
SC-5B30-04	4	-10	mV
SC-5B30-05	20	-50	mV
SC-5B30-06	40	-100	mV
Isolated Wideband Millivolt (5 V Current Requirement, 30 mA)			
SC-5B40-01	2	0	mV
SC-5B40-02	10	0	mV
SC-5B40-03	20	0	mV
SC-5B40-04	4	-10	mV
SC-5B40-05	20	-50	mV
SC-5B40-06	40	-100	mV
Isolated Linearized T/C Input (5 V Current Requirement, 30 mA)			
SC-5B47-J-01	152	0	°C
SC-5B47-J-02	80	-100	°C
SC-5B47-J-03	100	0	°C
SC-5B47-K-04	200	0	°C
SC-5B47-K-05	100	0	°C
SC-5B47-T-06	100	-100	°C
SC-5B47-T-07	40	0	°C
SC-5B47-E-08	200	0	°C
SC-5B47-R-09	250	+500	°C
SC-5B47-S-10	250	+500	°C
SC-5B47-S-11	260	+500	°C
Isolated RTD Input (5 V Current Requirement, 30 mA)			
SC-5B34-01	40	-100	°C
SC-5B34-02	20	0	°C
SC-5B34-03	40	0	°C
SC-5B34-04	120	0	°C
SC-5B34-C-01	24	0	°C
SC-5B34-C-02	24	0	°C
SC-5B34-N-01	24	0	°C
Isolated Current Input (5 V Current Requirement, 30 mA)			
SC-5B32-01	3.2	4	mA
SC-5B32-02	4	0	mA
Voltage Switch Input			
SC-AC-1367	1	0	V

DBK44 – Specifications

Name/Function: 2-Channel 5B Signal Conditioning Card

Module Capacity: 2 “input only” 5B modules

Weight: 0.25 kg (8 oz.) with no modules installed

Cable (optional): CA-37-x

DC Input Fuse: 4 A

Connections:

Male DB37 mates via CA-37-1 cable with P1 on the LogBook, DaqBook, ISA-type DaqBoard*, or Daq PC-Card.

User connections include 8 screw-terminals (4 per channel).
Screw terminations, per channel, are: +EXC, +Vin, -Vin, -EXC

Isolation to Primary Acquisition Device (LogBook or Daq Device):

Input Power: 0 VDC

Signal Inputs: 1500 VDC

Input Channel-to-Channel: 500 VDC

Environmental:

Operating Temperature: 0 to 50°C

Humidity: 0 to 80% RH @ 30°C; de-rate 3%/°C

Altitude: 0 to 2000 m

***Note:** For DaqBoard/2000 Series and /2000c Series boards, the use of a DBK200 Series P4-to-P1 adapter is required.

